

**FLEXIBLE
TRAINING
SYSTEM**

CABLE STATIONS

EVOST III

DHZ CABLE STATIONS EVOST III SERIES

Cable stations are a must in every fitness club because they offer very flexible training options and an even training weight throughout the entire movement sequence.

Consequently, it's not surprising that cable stations are the centrepiece of many studios and prove to be an excellent investment due to the high degree of utilisation in the studio. With 9 ready-made configurations, the new series offers the possibility of designing ergonomic solutions, especially in difficult, angled rooms or rooms with columns.

THE FACTS

- ✓ 9 READY-MADE CONFIGURATIONS
- ✓ UNLIMITED NUMBER OF CONFIGURATIONS ACCORDING TO CUSTOMER REQUIREMENTS
- ✓ FLEXIBLE SYSTEM: FUNCTIONALITIES CAN BE MOUNTED AT ANY POSITION ON THE TOWER
- ✓ NEW SHORT CONNECTIONS
- ✓ NEW 45° ANGLED CONNECTIONS
- ✓ ADDITIONAL WEIGHT 1.25 KG AND 2.5 KG
- ✓ HANDLES FOR MANY EXERCISES
- ✓ ADDITIONAL WALL AS A VARIABLY CUSTOMISABLE, CLEARLY ARRANGED GRIP RACK

THE BENEFITS

Additionally, its innovative product design allows for flexible system configuration, enabling every functionality in a four-tower setup to be variably positioned in any location.

DHZ also offers innovative connection solutions, which means that "short" connections (narrow cable run) or "diagonal" connections at a 45° angle are now also possible.

Free configurations: If you don't like any of the ready-made configurations, the new system can be customised to suit your requirements at no extra cost.

Furthermore, additional handles and additional weights have been provided for the user for more comfort during training. The new variable wall for hand grips offers the option of easily inserting the hooks into a grid in order to hang up all grip variants clearly and neatly, thus ensuring that they are organised and easy to find.

**MAXIMUM FLEXIBILITY,
UNLIMITED INDIVIDUALITY.
YOUR PERFECT
TRAINING SYSTEM!**

SCAN
FOR MORE
INFORMATION



» DHZ FITNESS SMART GYM SOLUTIONS

WITH OUR SMART GYM SOLUTIONS CONCEPT, WE TAKE THE PERSPECTIVE OF THE GYM OPERATOR AND DEVELOP SOLUTIONS THAT MAKE YOUR EVERYDAY LIFE EASIER. FOR YOUR MEMBERS, WE CREATE A PLEASANT TRAINING EXPERIENCE WITH AN EASY UNDERSTANDING OF PRODUCT USAGE AND GOOD TRAINING COMFORT.

STATION CABLE TOWER

A FLEXIBLE TRAINING SYSTEM WITH INTERCHANGEABLE MODULES THAT CAN BE CUSTOMISED ACCORDING TO CUSTOMER REQUIREMENTS. INNOVATIVE CONNECTION SOLUTIONS MAKE THE SYSTEM EVEN MORE SPACE-SAVING AND EFFICIENT.

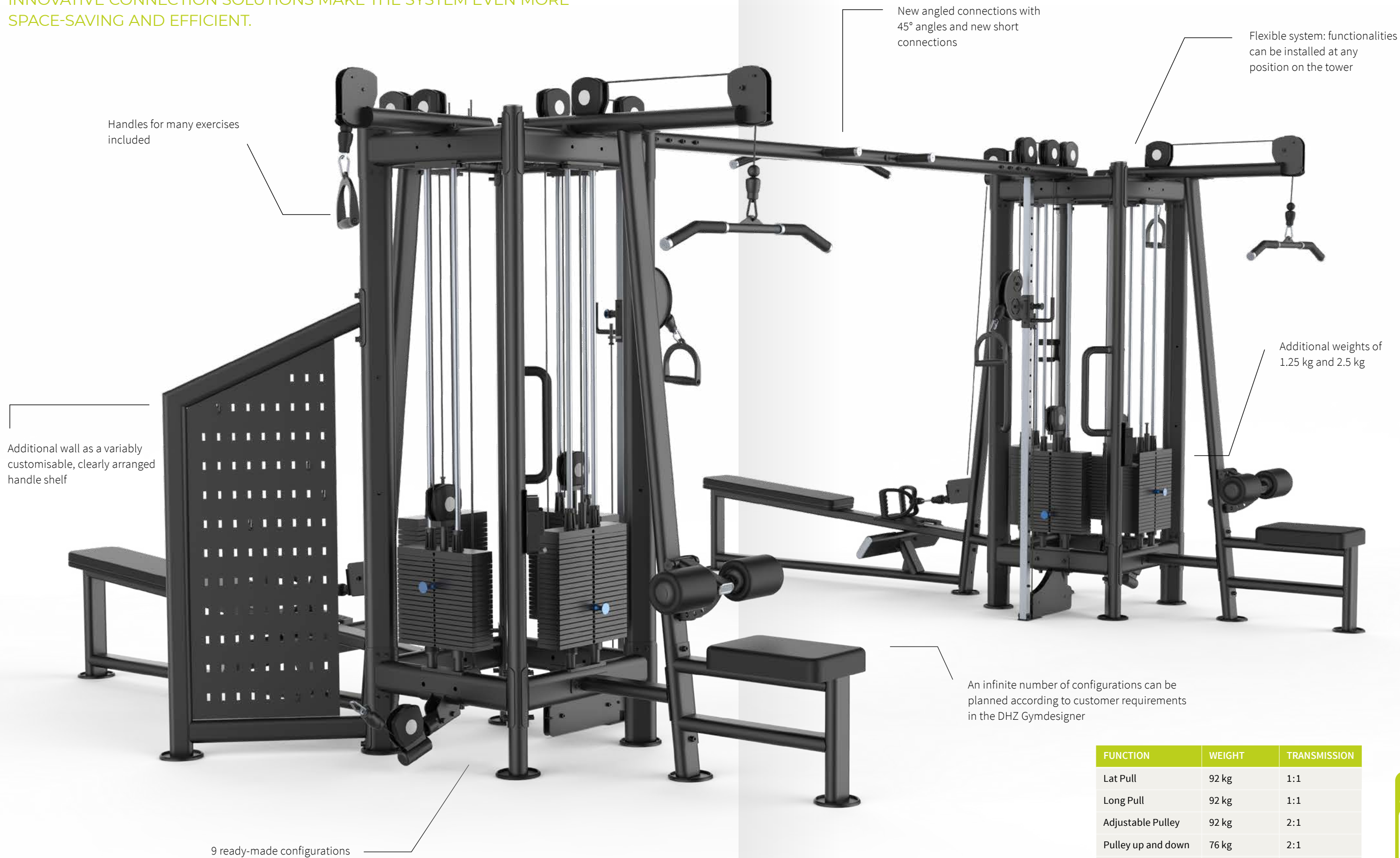

9 ready-made configurations

FUNCTION	WEIGHT	TRANSMISSION
Lat Pull	92 kg	1:1
Long Pull	92 kg	1:1
Adjustable Pulley	92 kg	2:1
Pulley up and down	76 kg	2:1
Triceps	52 kg	1:1



4 STATION CABLE TOWER

U2029

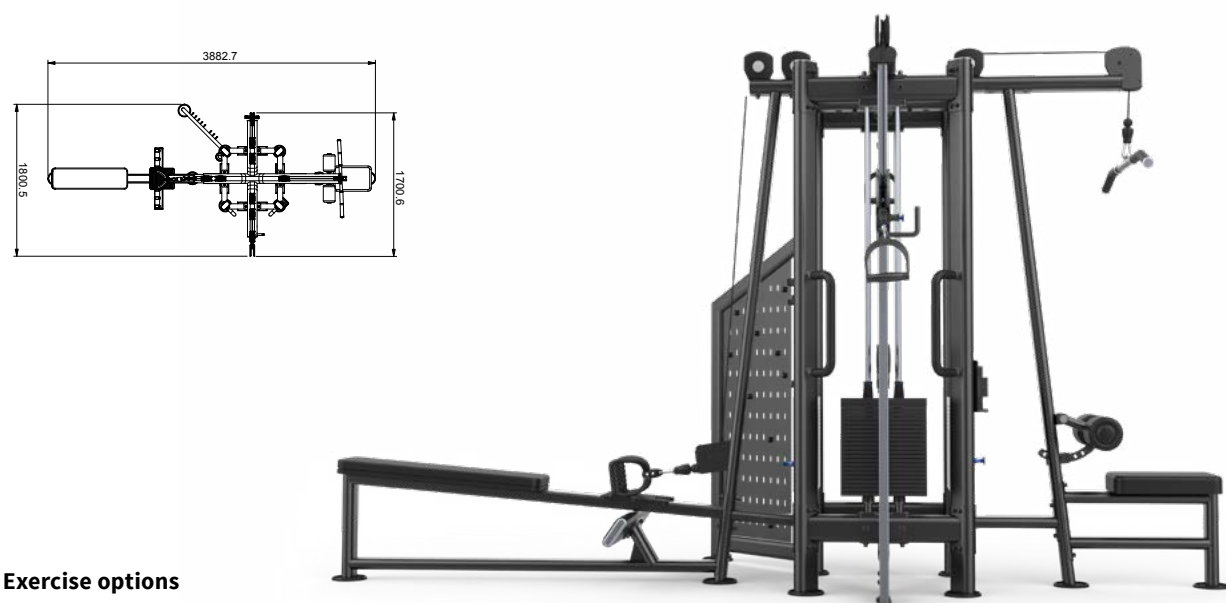

Exercise options

- Lat Pull
- Long Pull
- Adjustable Pulley
- Pulley Up & Down.

The four-station can be freely configured to accept any combination, for example 2x Lat Pull and 2x Long Pull.

MODEL	DIMENSIONS	TOTAL WEIGHT
U2029	180 x 390 cm	605 kg

6 STATION CABLE TOWER

U2066P



Exercise options

- Lat Pull
- Long Pull
- 4x Adjustable Pulley narrow Cable Pull
- Wide Cable Pull

MODEL	DIMENSIONS	TOTAL WEIGHT
U2066P	640 x 395 cm	1221 kg

5 STATION CABLE TOWER

U2066



Exercise options

- Lat Pull
- Long Pull
- 2x Adjustable Pulley
- Pulley Up & Down wide Cable Pull

MODEL	DIMENSIONS	TOTAL WEIGHT
U2066	490 x 390 cm	908 kg

8 STATION CABLE TOWER

U2066PA



Exercise options

- 2x Lat Pull
- Long Pull
- Triceps
- 2x Adjustable Pulley
- 2x Pulley Up & Down wide Cable Pull

MODEL	DIMENSIONS	TOTAL WEIGHT
U2066PA	580 x 390 cm	1135 kg

8 STATION CABLE TOWER

U2066PF

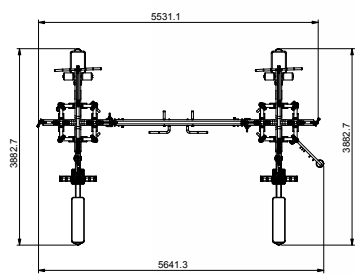

Exercise options

- 2x Lat Pull
- 2x Long Pull
- 2x Adjustable Pulley
- 2x Pulley Up & Down Wide Cable Pull

MODEL	DIMENSIONS	TOTAL WEIGHT
U2066PF	599 x 390 cm	1205 kg

9 STATION CABLE TOWER

U2066PB

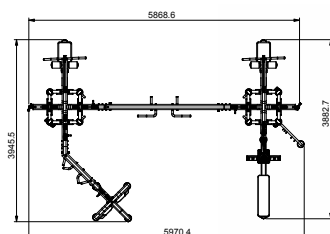

Exercise options

- 2x Lat Pull
- Long Pull
- 4x Adjustable Pulley
- 2x Pulley Up & Down narrow Cable Pull
- 2x Wide Cable Pull

MODEL	DIMENSIONS	TOTAL WEIGHT
U2066PB	597 x 395 cm	1469 kg

10 STATION CABLE TOWER

U2066PE

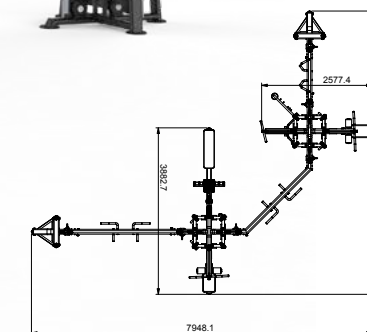

Exercise options

- 2x Lat Pull
- Long Pull
- Triceps
- 6x Adjustable Pulley narrow Cable Pull
- 2x Wide Cable Pull

MODEL	DIMENSIONS	TOTAL WEIGHT
U2066PE	815 x 685 cm	1785 kg

13 STATION CABLE TOWER

U2066PC

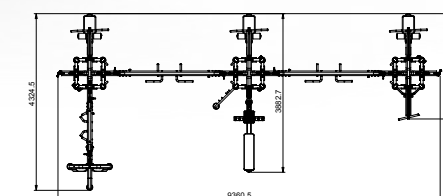

Exercise options

- 3x Lat Pull
- Long Pull
- Triceps
- 6x Adjustable Pulley
- 2x Pulley Up & Down narrow Cable Pull
- 2x Wide Cable Pull

MODEL	DIMENSIONS	TOTAL WEIGHT
U2066PC	936 x 433 cm	2032 kg



DHZ FITNESS SHOWROOM

Eisenhutweg 122
12487 Berlin

- more than 700 m²
- only 10 minutes from airport

YOU WANT TO GET TO KNOW AND TEST OUR EQUIPMENT?

Come visit us!

In our showroom in Berlin, we present a selection of our equipment. Please contact us for a personal appointment so that we can take the time to advise you competently.

YOU ARE INTERESTED IN ADDITIONAL INFORMATION OR WANT TO MEET IN PERSON?

Ask us!

Our friendly sales team is available for you to address your needs. We would be happy to make a non-binding offer to you.

DHZ FITNESS EUROPE GMBH

Berliner Straße 8D | 16727 Velten

☎ 03304-247 28 76 | ✉ sales@dhz-fitness.de

WWW.DHZ-FITNESS.DE
WWW.DHZ-FITNESS.EU



SCAN
FOR MORE
INFORMATION

